



Renesas Electronics Corporation delivers trusted embedded design innovation with complete semiconductor solutions that enable billions of connected, intelligent devices to enhance the way people work and live. A global leader in microcontrollers, analog, power, and SoC products, Renesas provides comprehensive solutions for a broad range of automotive, industrial, infrastructure, and IoT applications that help shape a limitless future.



Würth Elektronik eiSos is one of the leading manufacturers of electronic and electromechanical components in Europe. The product portfolio includes: EMC Components, EMC Filters, Capacitors, Inductors, RF Inductors and LTCC Components, Resistors, Quartz, Oscillators, Transformers, Components for Circuit Protection, Power Modules, LEDs, Connectors, Switches, High-Power Contacts, Assembly Technique, Wireless Connectivity and Sensors.



SEGGER has over twenty-five years of experience in Embedded Systems, producing cutting-edge RTOS and Software Libraries, and offering a full set of hardware tools (for development and production) and software tools. The J-Link debug probes, with Ozone the accompanying debugger and performance analyzer, and Embedded Studio the powerful cross platform C/C++ IDE, are available to support developers in creating their own embedded systems.



	PRODUCT	M13-RA6M3-EK			DRAWN BY	PATRICK S.	DATE	2020.12.01
	PAGE	TECHNOLOGY PARTNERS			APPROVED BY	TONY P.	DATE	2021.03.02
	REFERENCE	VERSION	REV	REMARKS		UPDATED ON	SIZE	SHEET
	REN0001.2002	V1.0				2021.03.02	A4	1 OF 15

TABLE OF CONTENT

PAGE	DESCRIPTION
1	TECHNOLOGY PARTNERS
2	TABLE OF CONTENT
3	RA6M3 / SYSTEM
4	RA6M3 / GPIO1
5	RA6M3 / GPIO2
6	RA6M3 / GPIO DISTRIBUTION / MULTIPLEXING
7	RA6M3 / POWER
8	DEBUG & RESET
9	ETHERNET
10	DISPLAY / CAMERA
11	MEMORY
12	AUDIO CODEC
13	EXNPANSION INTERFACES / MEMS
14	POWER SUPPLY / RAIL
15	REVISION



	PRODUCT	M13-RA6M3-EK			DRAWN BY	PATRICK S.	DATE	2020.12.01
	PAGE	TABLE OF CONTENT			APPROVED BY	TONY P.	DATE	2021.03.02
	REFERENCE	VERSION	REV	REMARKS	UPDATED ON		SIZE	SHEET
	REN0001.2002	V1.0			2021.03.02		A4	2 OF 15

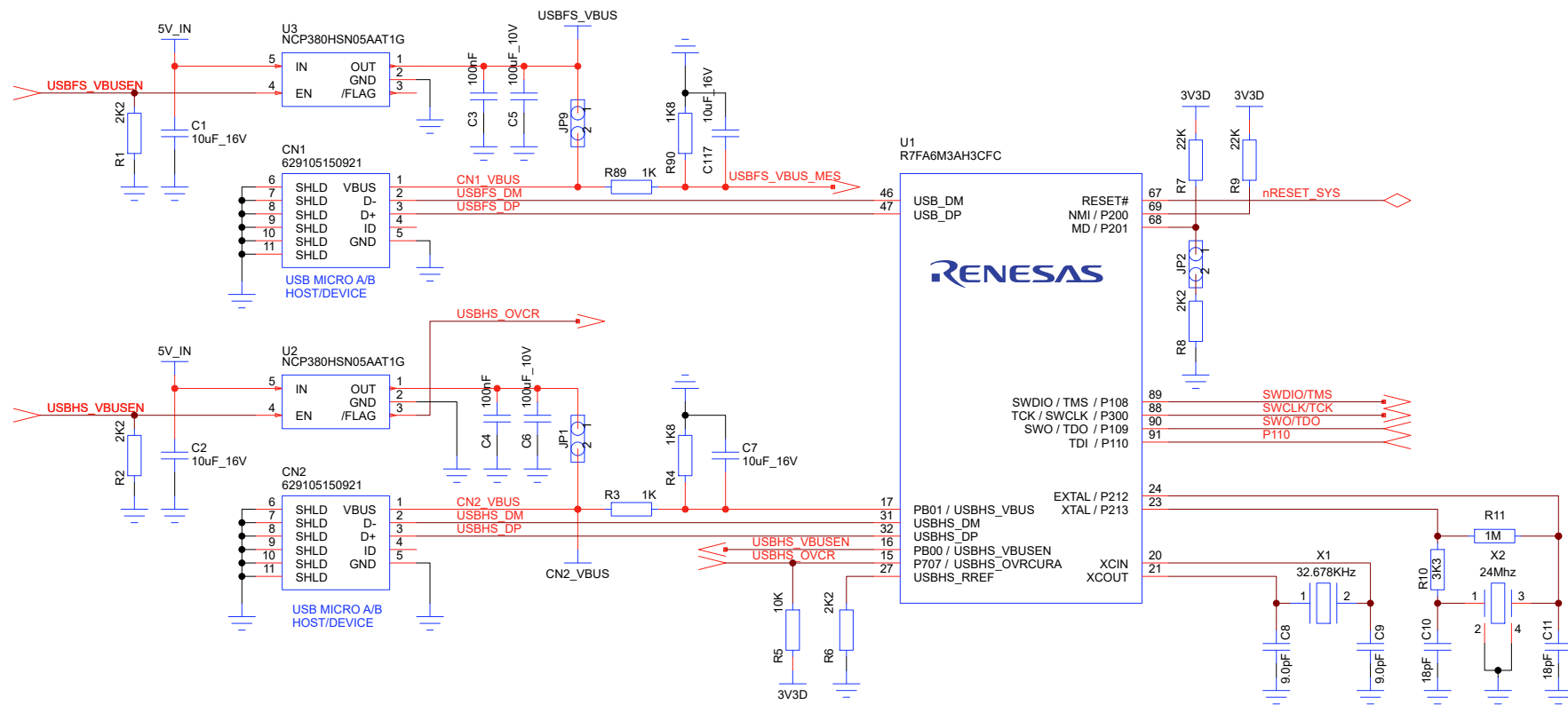

	PRODUCT	M13-RA6M3-EK			DRAWN BY	PATRICK S.	DATE	2020.12.01
	PAGE	RA6M3 / SYSTEM			APPROVED BY	TONY P.	DATE	2021.03.02
 www.m13design.fr	REFERENCE	VERSION	REV	REMARKS	UPDATED ON		SIZE	SHEET
	REN0001.2002	V1.0			2021.03.02		A4	3 OF 15

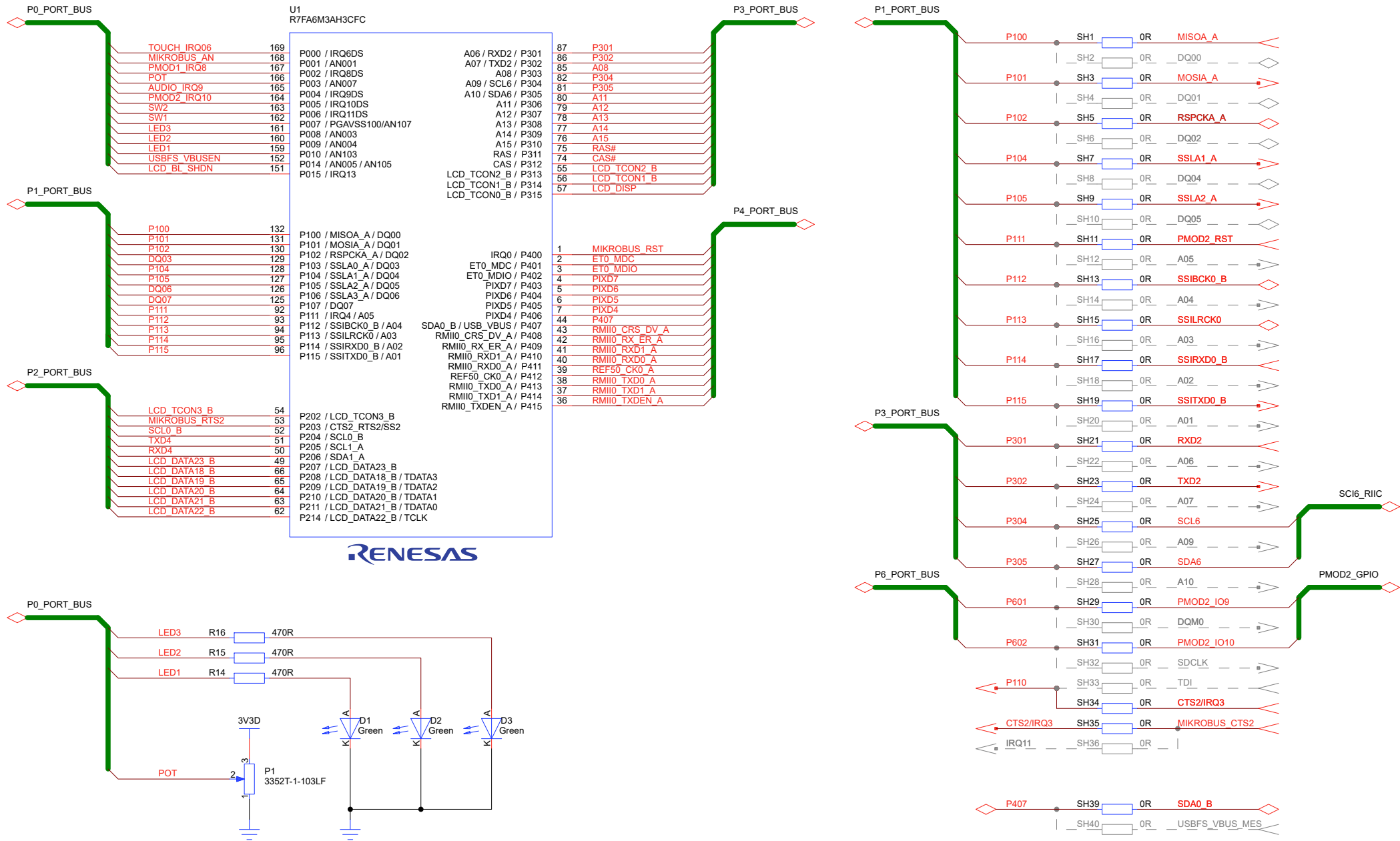

PRODUCT		M13-RA6M3-EK			DRAWN BY		PATRICK S.		DATE		2020.12.01	
PAGE		RA6M3 / GPIO1			APPROVED BY		TONY P.		DATE		2021.03.02	
 www.m13design.fr	REFERENCE	VERSION	REV	REMARKS	UPDATED ON		SIZE	SHEET				
	REN0001.2002	V1.0			2021.03.02		A4	4 OF 15				

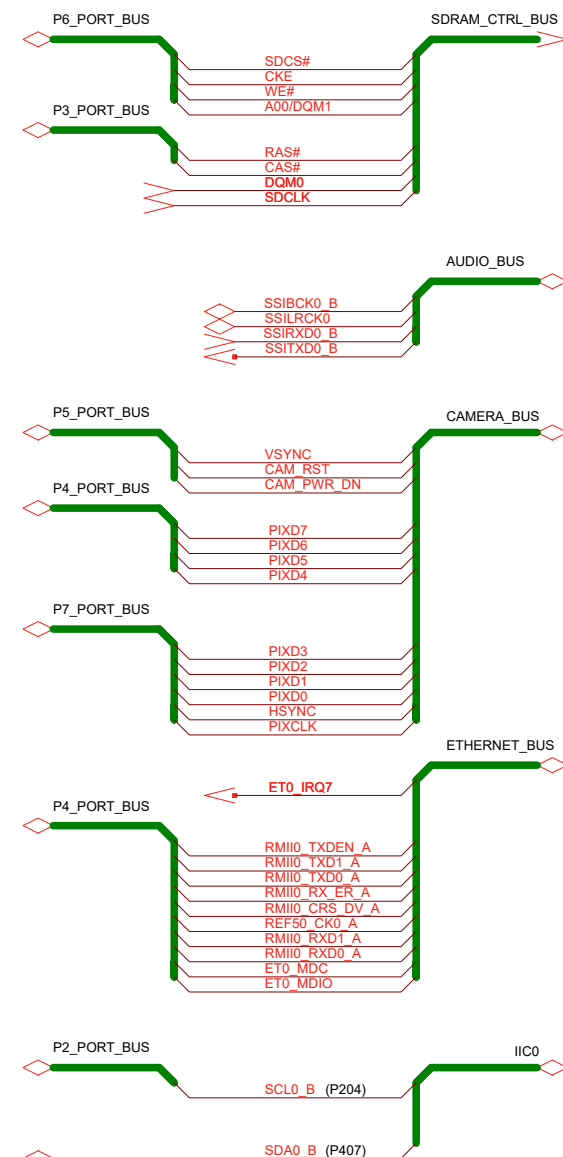
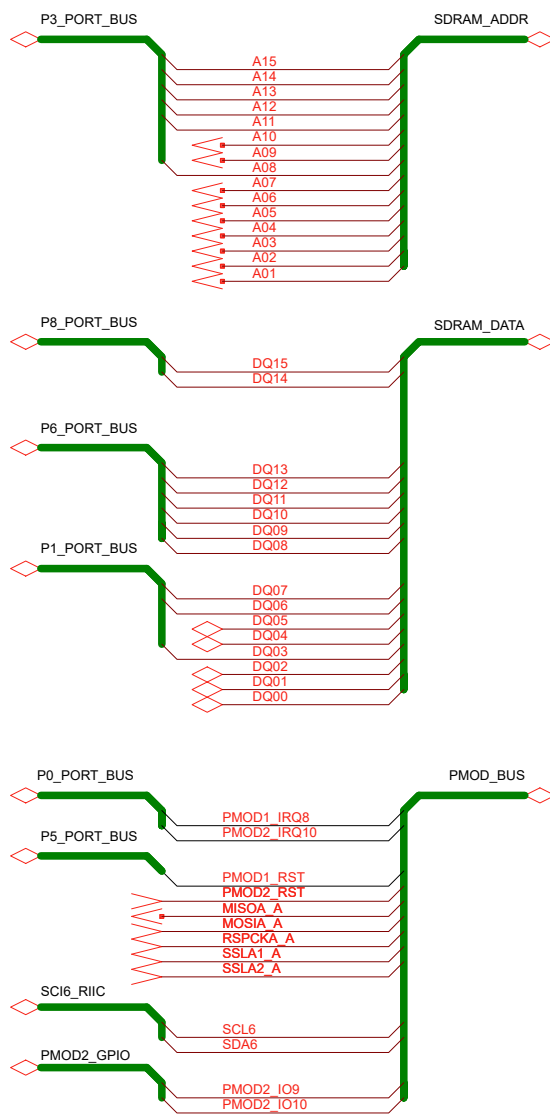
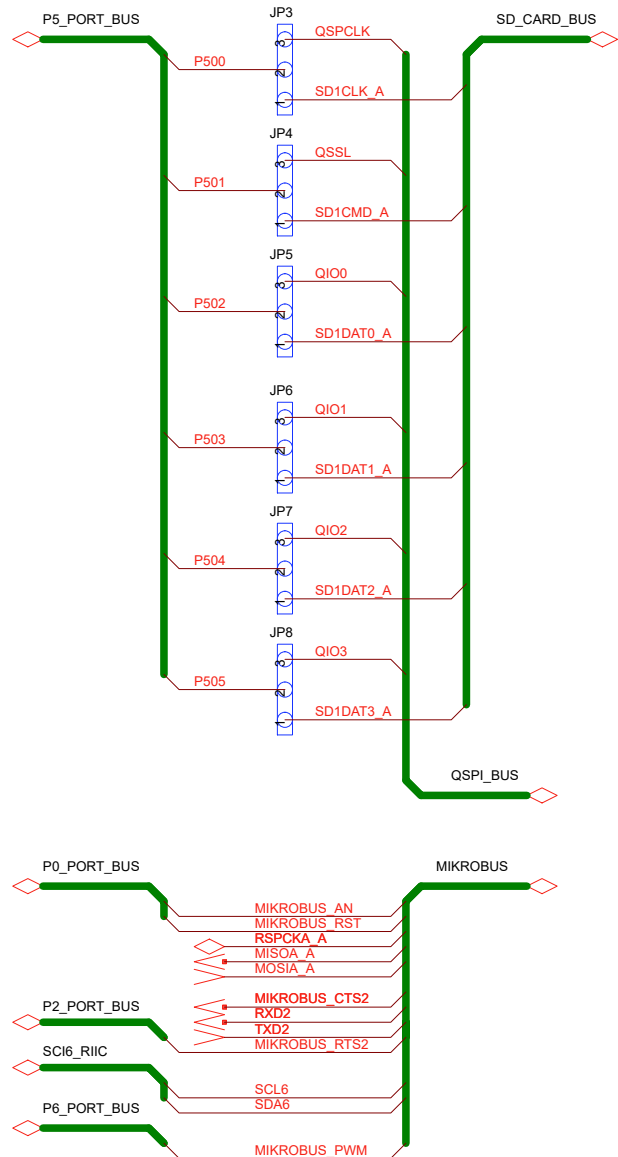

PRODUCT	M13-RA6M3-EK			DRAWN BY	PATRICK S.	DATE	2020.12.01
PAGE	RA6M3 / GPIO DISTRIBUTION / MULTIPLEXING			APPROVED BY	TONY P.	DATE	2021.03.02
REFERENCE	VERSION	REV	REMARKS	UPDATED ON		SIZE	SHEET
REN0001.2002	V1.0			2021.03.02		A4	6 OF 15

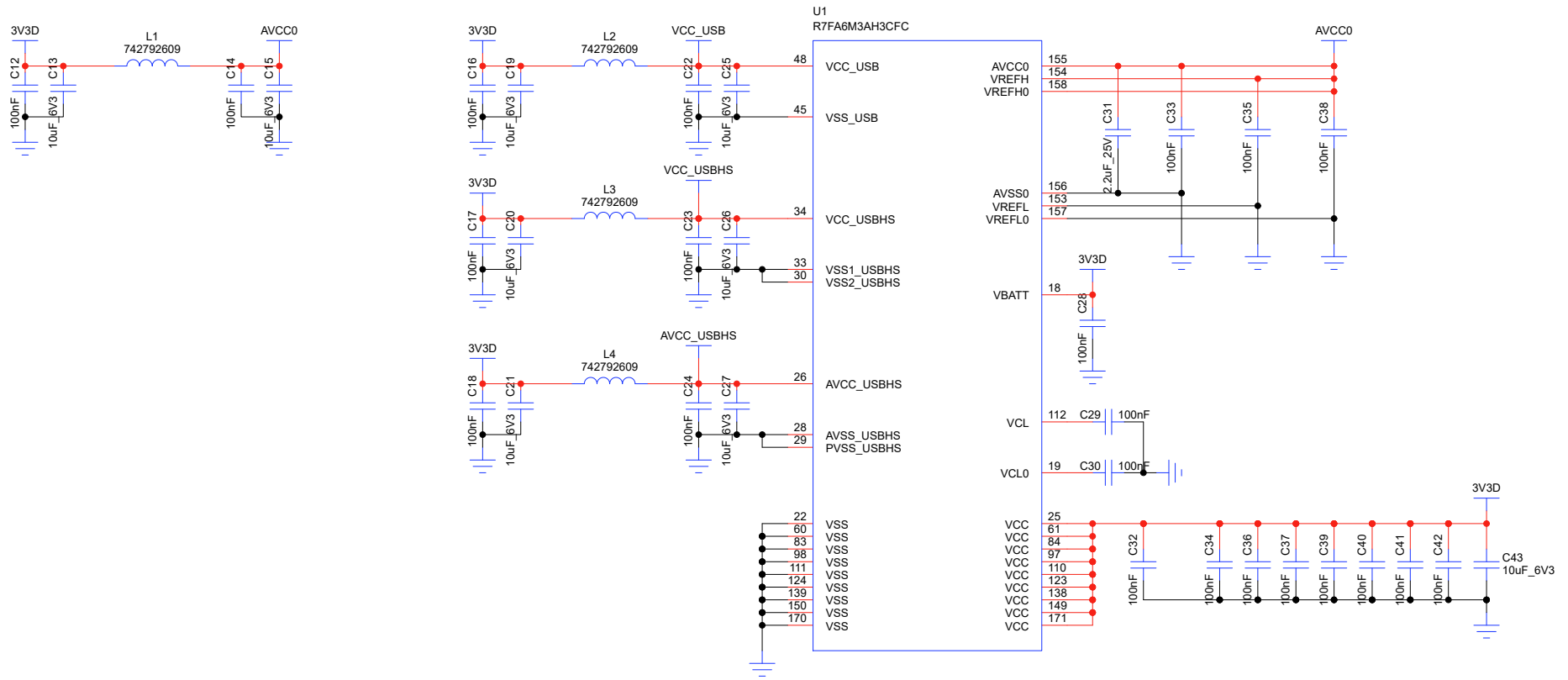

	PRODUCT	M13-RA6M3-EK			DRAWN BY	PATRICK S.	DATE	2020.12.01
	PAGE	RA6M3 / POWER			APPROVED BY	TONY P.	DATE	2021.03.02
 www.m13design.fr	REFERENCE	VERSION	REV	REMARKS	UPDATED ON		SIZE	SHEET
	REN0001.2002	V1.0			2021.03.02		A4	7 OF 15

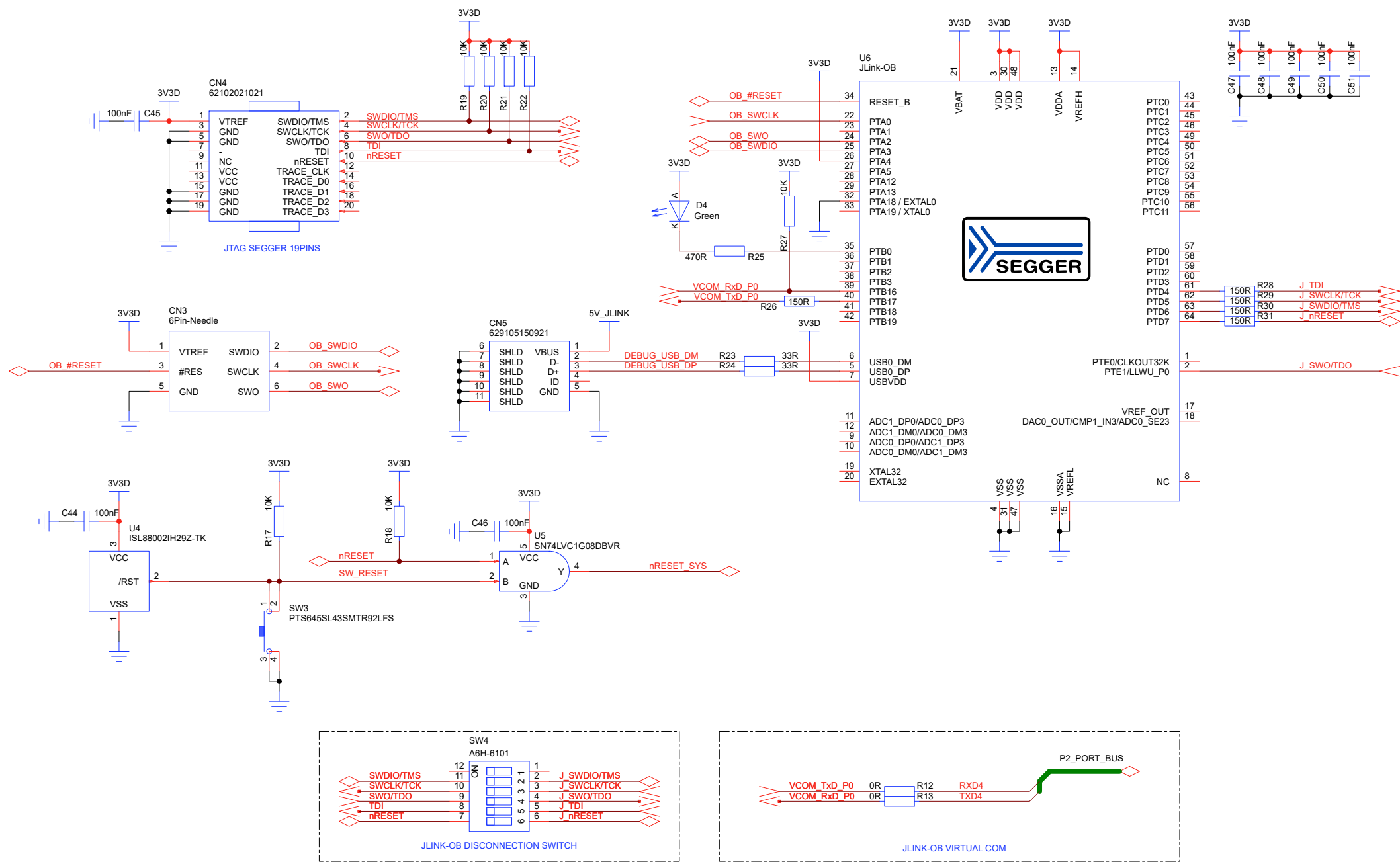

PRODUCT	M13-RA6M3-EK			DRAWN BY	PATRICK S.	DATE	2020.12.01
PAGE	DEBUG & RESET			APPROVED BY	TONY P.	DATE	2021.03.02
REFERENCE	VERSION	REV	REMARKS	UPDATED ON		SIZE	SHEET
REN0001.2002	V1.0			2021.03.02		A4	8 OF 15

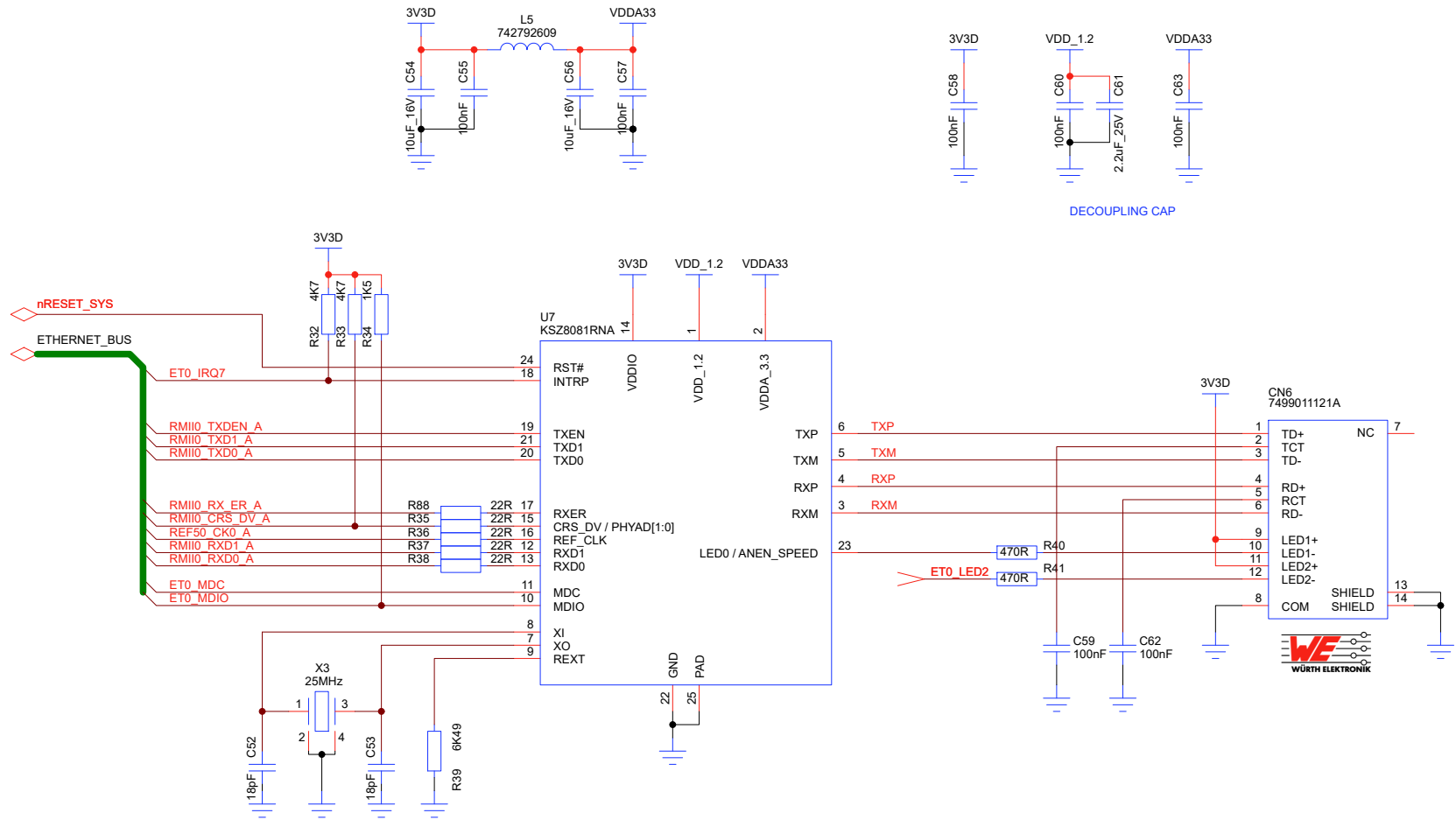

1	PRODUCT	M13-RA6M3-EK			DRAWN BY	PATRICK S.	DATE	2020.12.01
	PAGE	ETHERNET			APPROVED BY	TONY P.	DATE	2021.03.02
2	REFERENCE	VERSION	REV	REMARKS	UPDATED ON		SIZE	SHEET
	REN001.2002	V1.0			2021.03.02		A4	9 OF 15



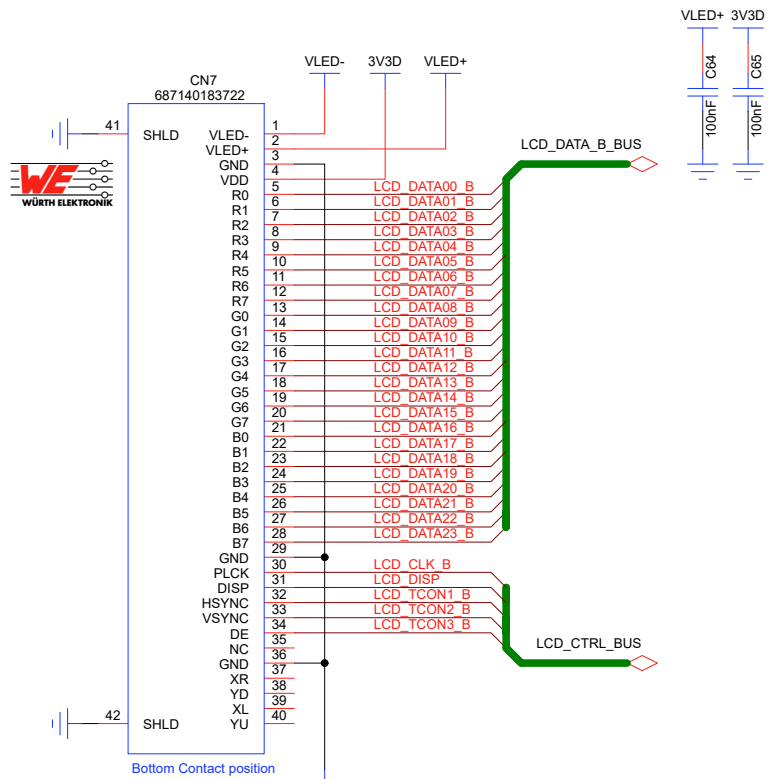

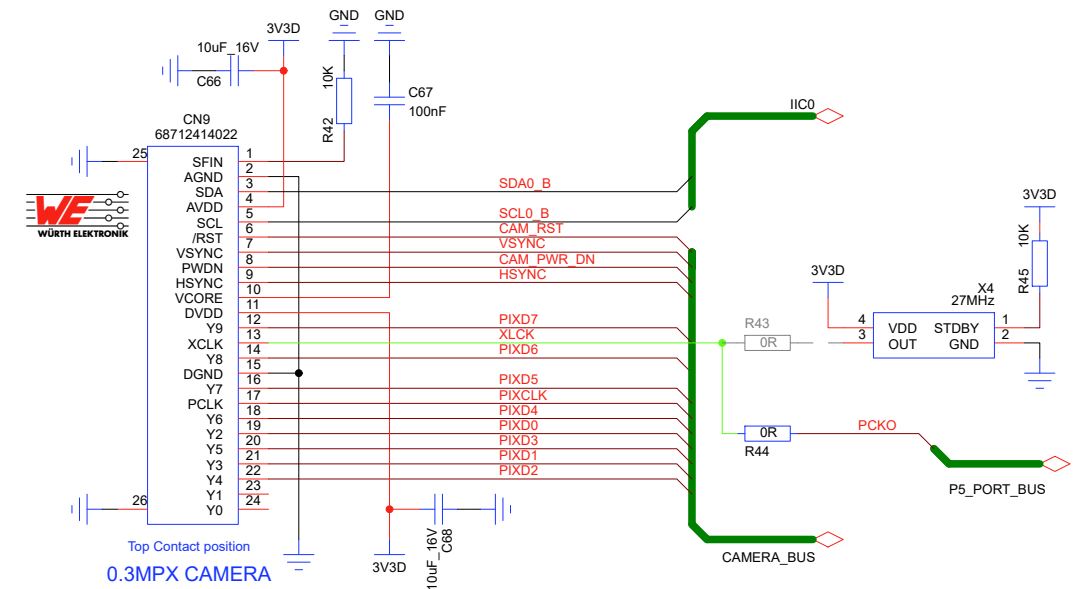

LCD CONNECTOR

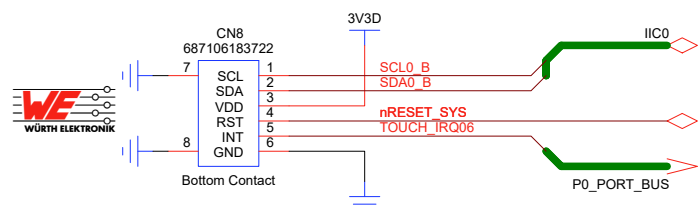

0.3MPX CAMERA



LCD CAPACITIVE TOUCH

 www.m13design.fr	PRODUCT	M13-RA6M3-EK			DRAWN BY	PATRICK S.	DATE	2020.12.01
	PAGE	DISPLAY / CAMERA			APPROVED BY	TONY P.	DATE	2021.03.02
REFERENCE	VERSION	REV	REMARKS			UPDATED ON	SIZE	SHEET
REN0001.2002	V1.0					2021.03.02	A4	10 OF 15

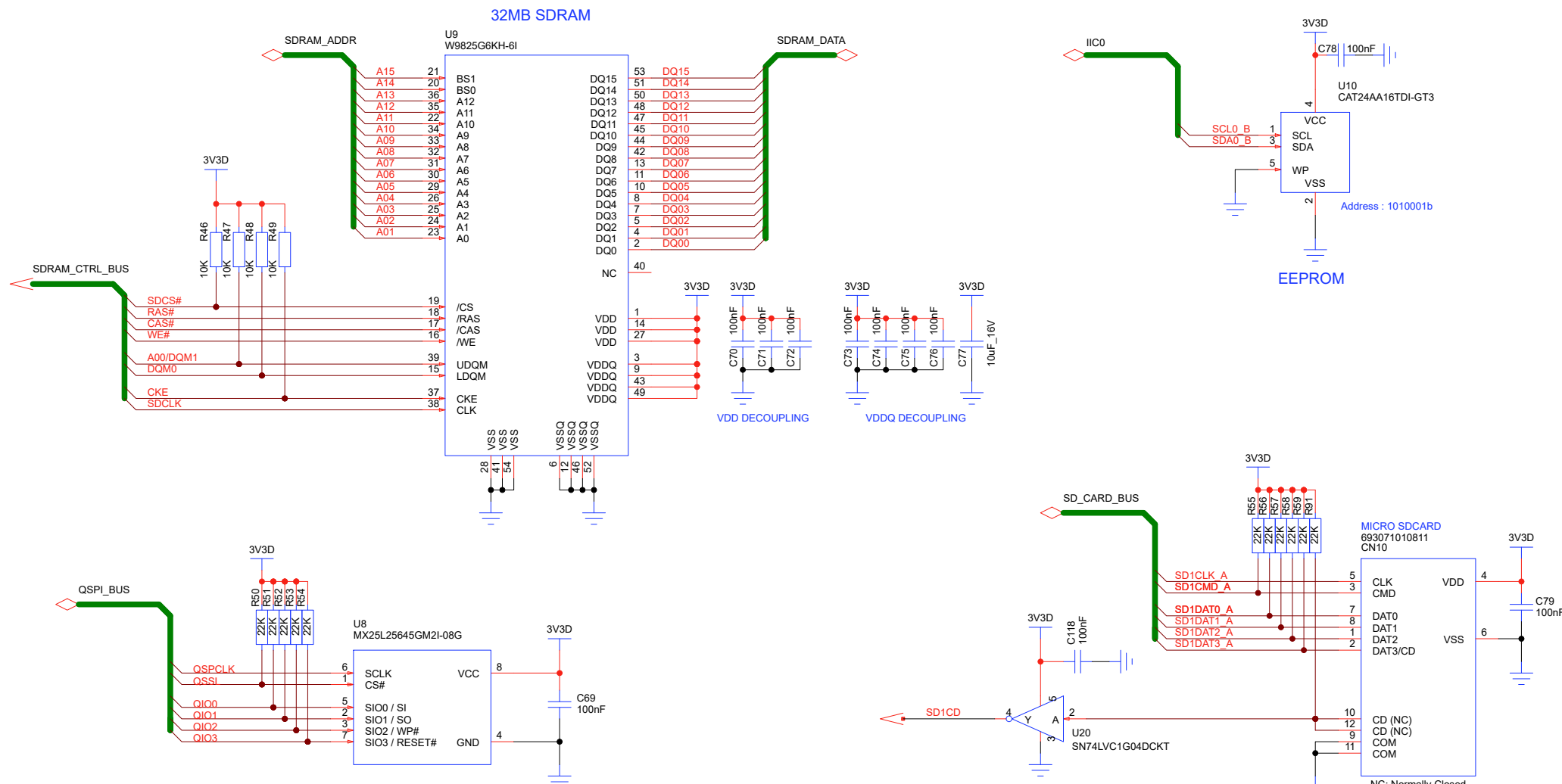

CD (CARD DETECTION)	
CARD REMOVED	CARD INSERTED
CLOSE	OPEN
SD1CD = 1	SD1CD = 0



PRODUCT	M13-RA6M3-EK	DRAWN BY	PATRICK S.	DATE	2020.12.01	
PAGE	MEMORY	APPROVED BY	TONY P.	DATE	2021.03.02	
REFERENCE	VERSION	REV	REMARKS	UPDATED ON	SIZE	SHEET
REN001.2002	V1.0			2021.03.02	A4	11 OF 15

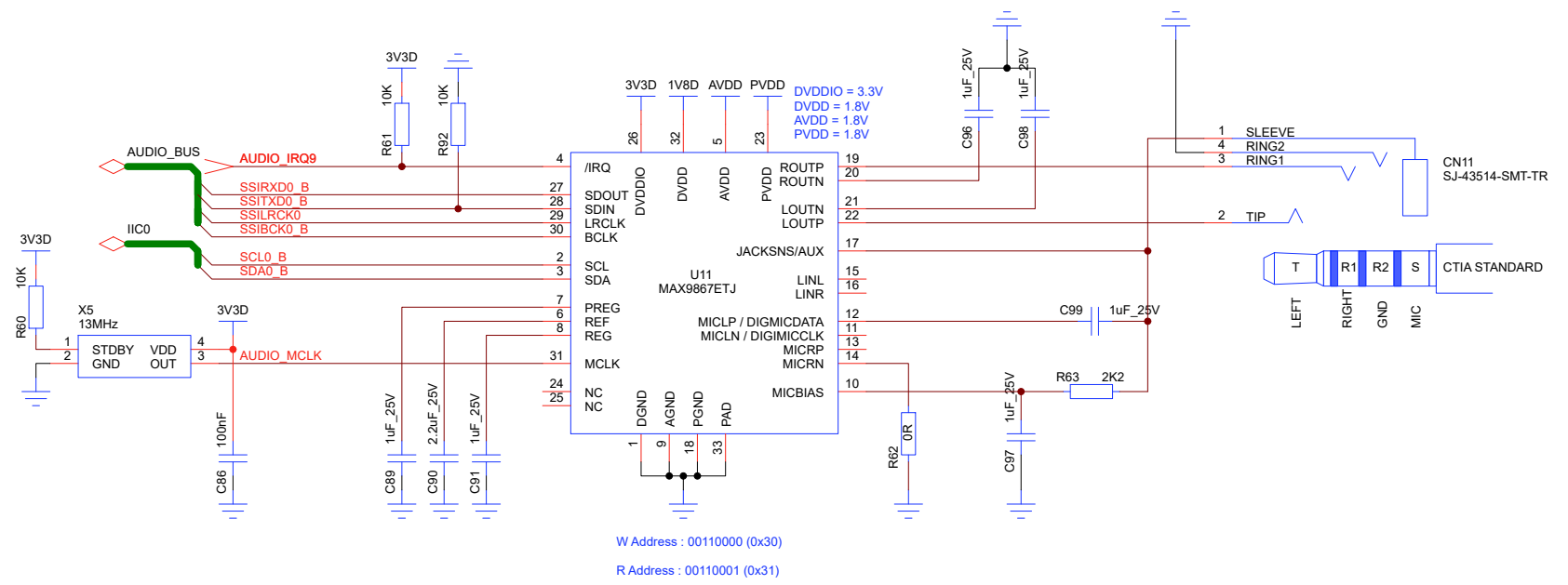
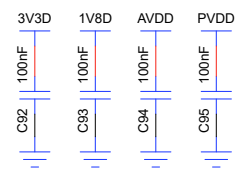
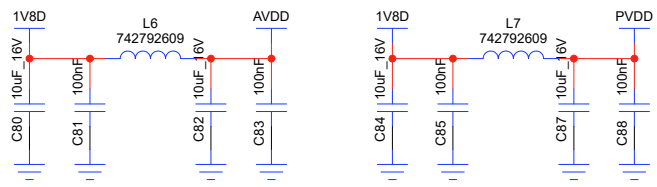

PRODUCT	M13-RA6M3-EK				DRAWN BY	PATRICK S.	DATE	2020.12.01
	PAGE	AUDIO				APPROVED BY		TONY P.
REFERENCE	VERSION	REV	REMARKS			UPDATED ON	SIZE	SHEET
	REN0001.2002	V1.0						



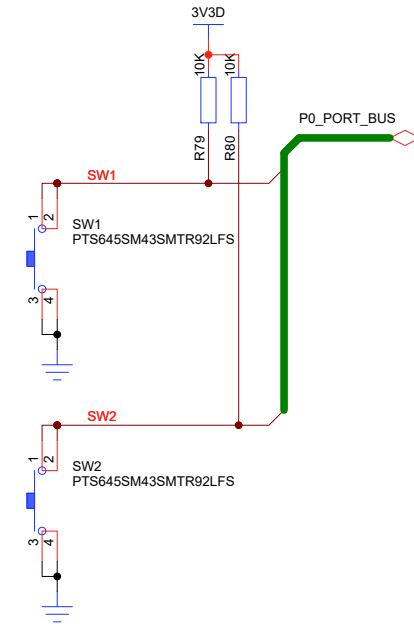
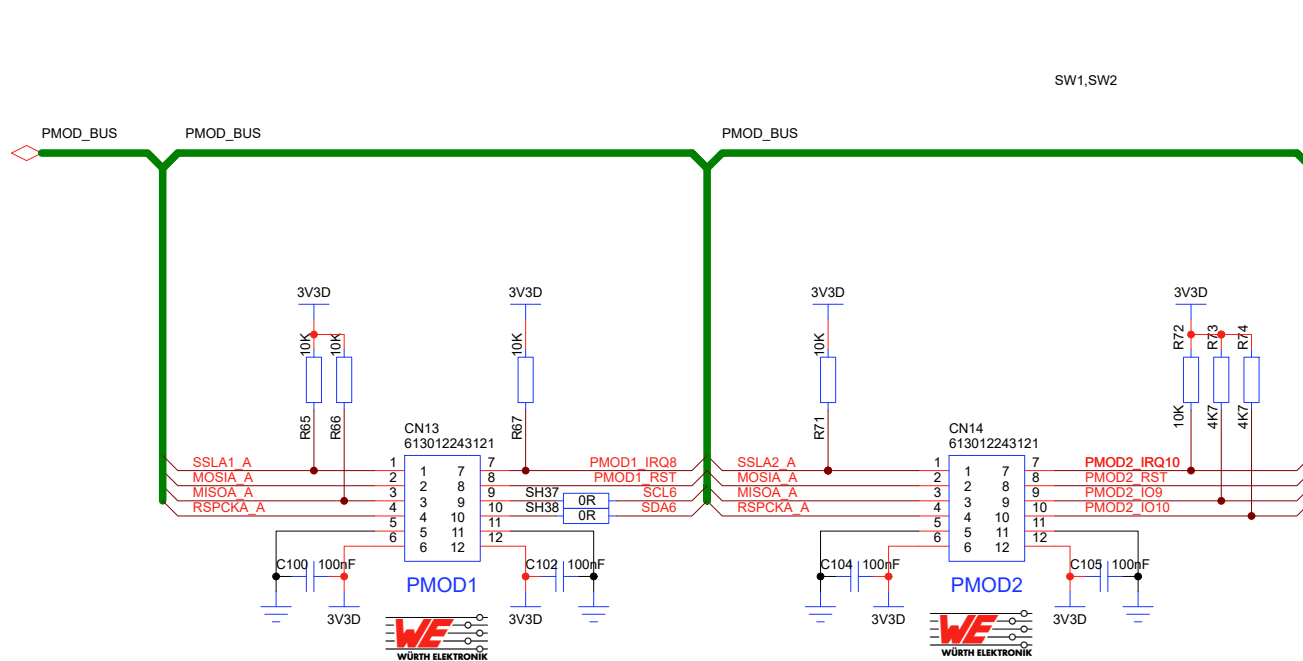
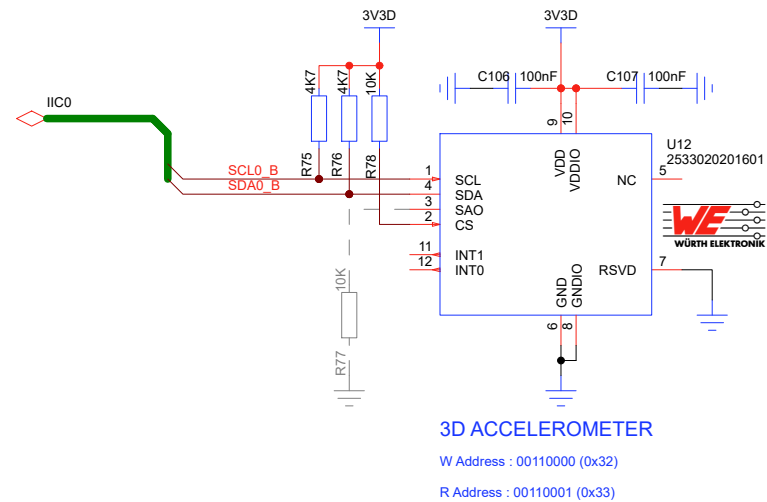
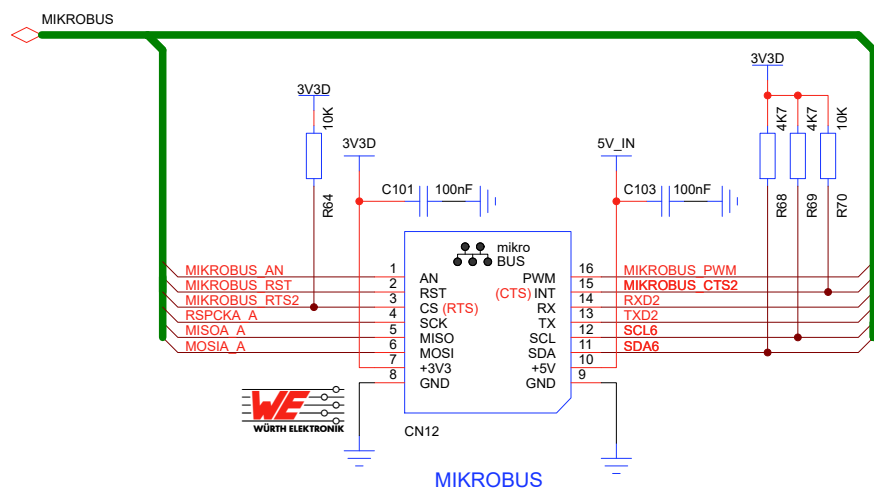

PRODUCT	M13-RA6M3-EK		
PAGE	EXPANSION INTERFACES / MEMS / SW		
REFERENCE	VERSION	REV	REMARKS
REN001.2002	V1.0		

DRAWN BY	PATRICK S.	DATE	2020.12.01
APPROVED BY	TONY P.	DATE	2021.03.02
UPDATED ON	SIZE	SHEET	
2021.03.02	A4	13 OF 15	

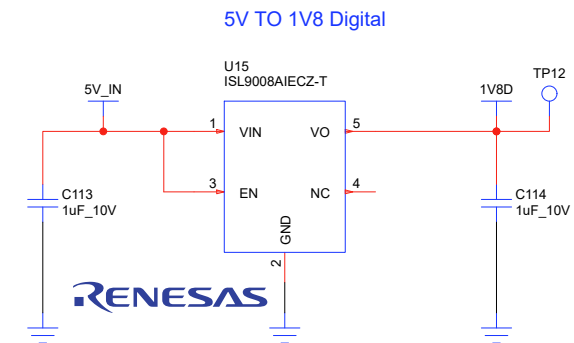
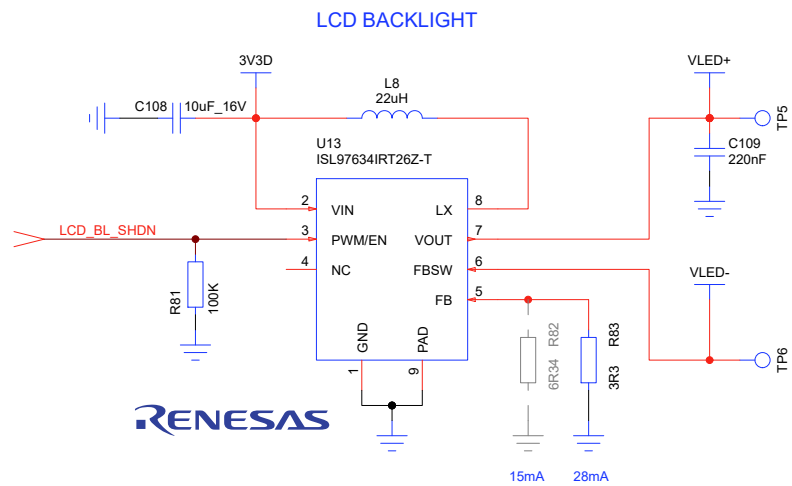
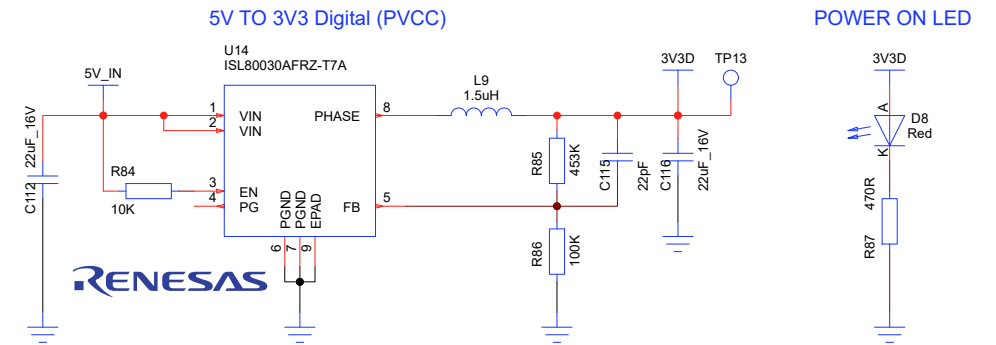
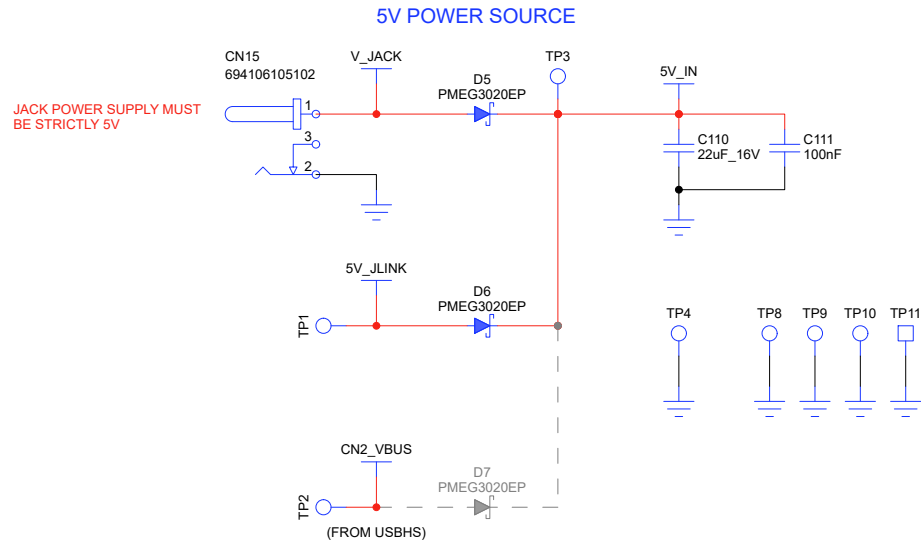

PRODUCT	M13-RA6M3-EK			DRAWN BY	PATRICK S.	DATE	2020.12.01
PAGE	POWER SUPPLY / RAIL			APPROVED BY	TONY P.	DATE	2021.03.02
REFERENCE	VERSION	REV	REMARKS	UPDATED ON		SIZE	SHEET
REN0001.2002	V1.0			2021.03.02		A4	14 OF 15

REVISION HISTORY

DATE	VERSION	CHANGES
2021.01.12	V1.0	Initial Version
2021.03.02	V1.0	Added PMOD_BUS page 6 / P706 Multiplexed between Ethernet IRQ (IRQ_ETH) and SDHI Card Detect (SD1CD) Added Inverter gate on SD1CD signal as CN10 Card Detect function is mechanically inverted / R43 is not fitted by default Added Pull-down on SSITXD0_B in order to avoid hi-Z output during the SSIE Idle state



	PRODUCT	M13-RA6M3-EK			DRAWN BY	PATRICK S.	DATE	2020.12.01
	PAGE	REVISION			APPROVED BY	TONY P.	DATE	2021.03.02
	REFERENCE	VERSION	REV	REMARKS		UPDATED ON	SIZE	SHEET
	REN0001.2002	V1.0				2021.03.02	A4	15 OF 15